

LUG SCHEDULE

SWITCH SIZE	CABLE CONNECTION SIZE SOURCE 1, LOAD & SOURCE 2 PER PHASE & NEUTRAL	GROUND	ESTIMATED NET WEIGHT (lbs.)
225-400A	(1) #4-600MCM OR (2) #1/0-250MCM	(3) #14-1/0	979
600A	(2) #4-500MCM	(6) #6-250MCM	979
800A	(2) #4-600MCM OR (4) #1/0-250MCM	(6) #6-250MCM	979

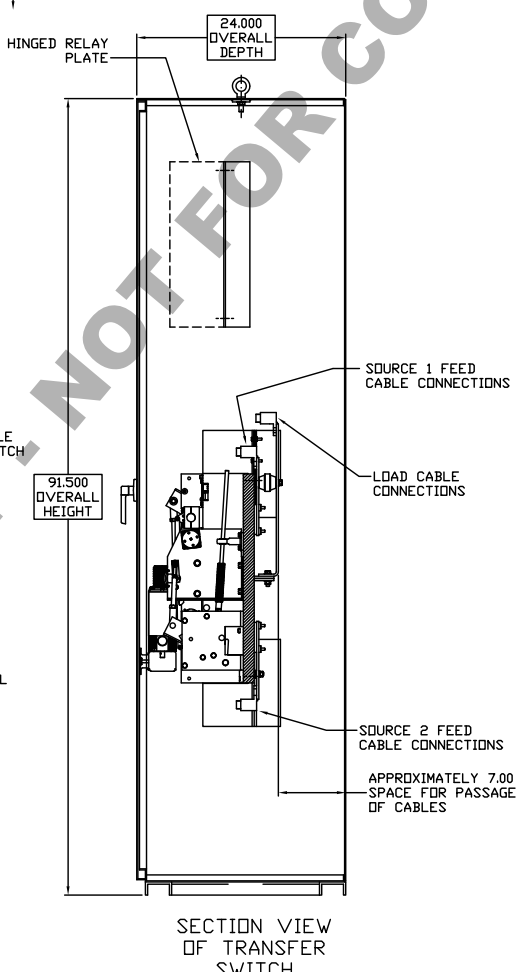
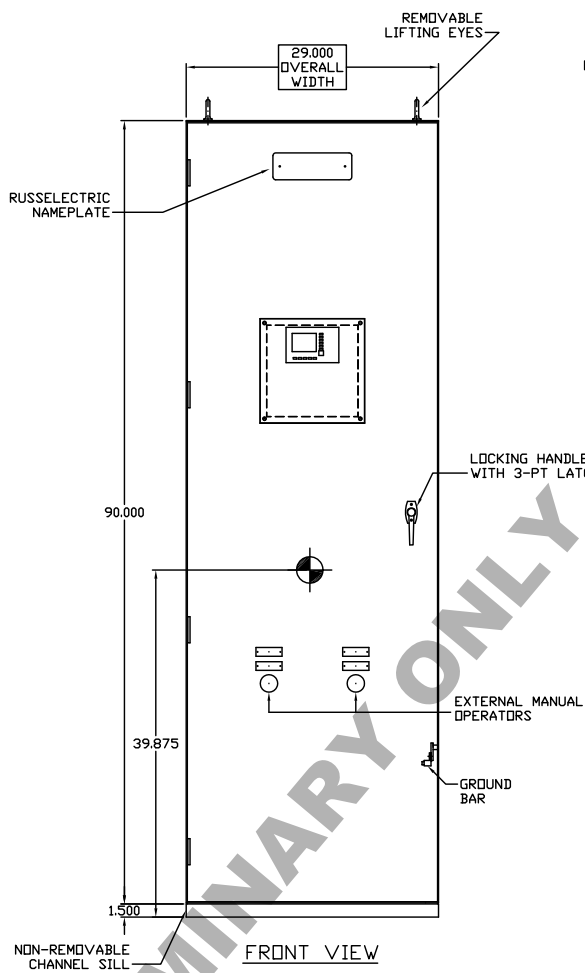
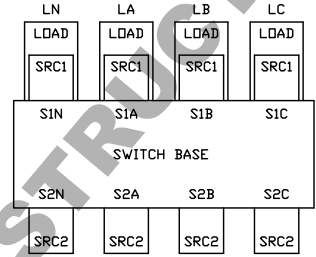
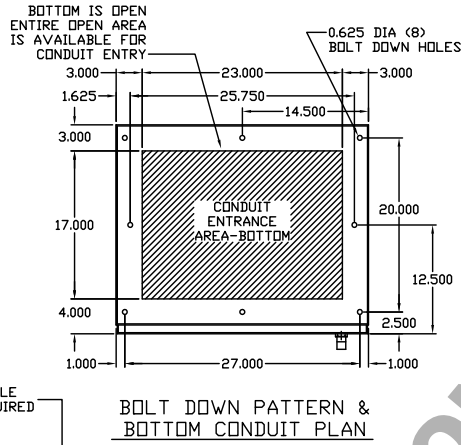
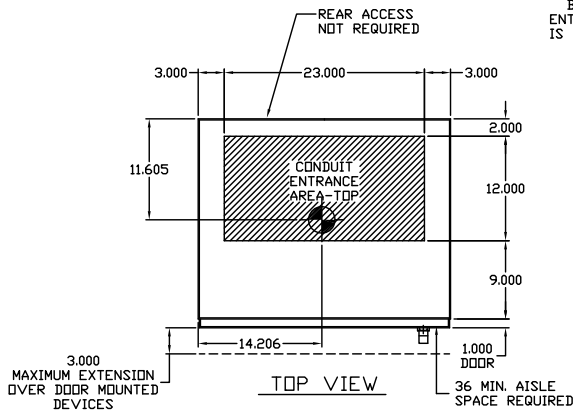

GENERAL NOTES:

- ENCLOSURE FABRICATED FROM SHEET STEEL IN ACCORDANCE WITH UL STANDARD 508.
- ALL STEEL PARTS SHALL BE PREPARED FOR PAINTING BY A FIVE STEP CLEANING, PHOSPHATIZING AND SEALING PROCESS. THE PARTS SHALL THEN BE PAINTED ASA #61 GRAY, UTILIZING POLYESTER POWDER COATING APPLIED BY THE ELECTROSTATIC METHOD AND CURED IN A BAKING OVEN. THIS FINISH IS SUITABLE FOR OUTDOORS, AS WELL AS INDOOR APPLICATIONS.
- LUG SIZES SPECIFIED ARE MECHANICAL TYPE SUITABLE FOR CU/AL CABLE.
- ALL DIMENSIONS ARE IN INCHES (1 INCH = 2.54 CM)
- SPECIAL CONSIDERATION MUST BE TAKEN WHEN PREPARING THE FOUNDATION. FOLLOW ALL APPLICABLE LOCAL AND INTERNATIONAL BUILDING CODES.

- WHEN ANCHORING FOR A SEISMIC LOCATION, CONSIDERATION MUST BE GIVEN TO THE DESIGN OF THE PAD OR FOUNDATION. MINIMUM CONCRETE THICKNESS AND PSI, MINIMUM ANCHOR EDGE DISTANCE, CENTERLINE SPACING, AND EFFECTIVE EMBEDMENT ARE ALL FACTORS THAT WILL INFLUENCE THE ANCHORING.
 - REFER TO THE PROJECT SPECIFIC SEISMIC STUDY DONE BY A CERTIFIED ENGINEER FOR PROPER ANCHOR DETAIL INFORMATION.
 - USE AN ANCHOR THAT MEETS OR EXCEEDS THE STRENGTH OF A 1/2-INCH GRADE 5 BOLT WITH A 1/2" USS LARGE FLAT WASHER.

SWITCH SIZE	NO. OF POLES	QUANTITY	SPECIAL MARKINGS
225-800A	4	1	

Russelectric
SOUTH SHORE PARK, HINGHAM, MA 02043
HTTP://WWW.RUSSELECTRIC.COM

NEMA 1 225-800A 4P (RTS30)
ATS FREESTANDING ENCLOSURE

DFTM.	MDM	1.26.09	DWG. 83S0034D24 D
CHKD.	JTL	03/04/11	
CERTIFIED BY:	DATE:	APPD.	SHEET NO. 1 CONT'D ON SHEET NO. 1 REV